

FOR AUSTRALIA (E) FOR EUROPE (G) FOR W. GERMANY (J) FOR USA (C) FOR CANADA

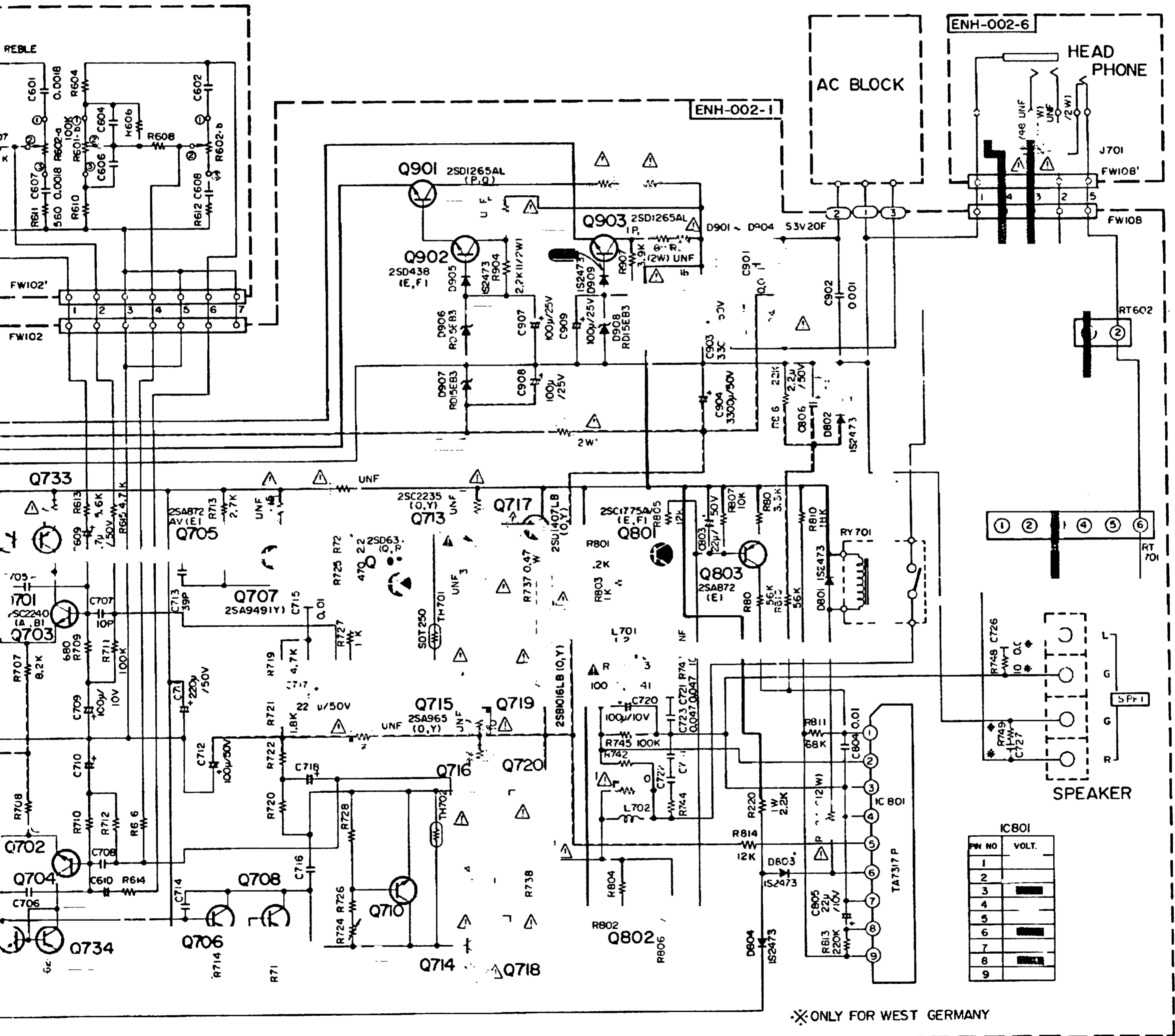

- 4. shows voltage values at no signal
 - 5. This is the standard circuit diagram.
- The design and contents are subject to change without notice

8. A-K11 Schematic Diagram

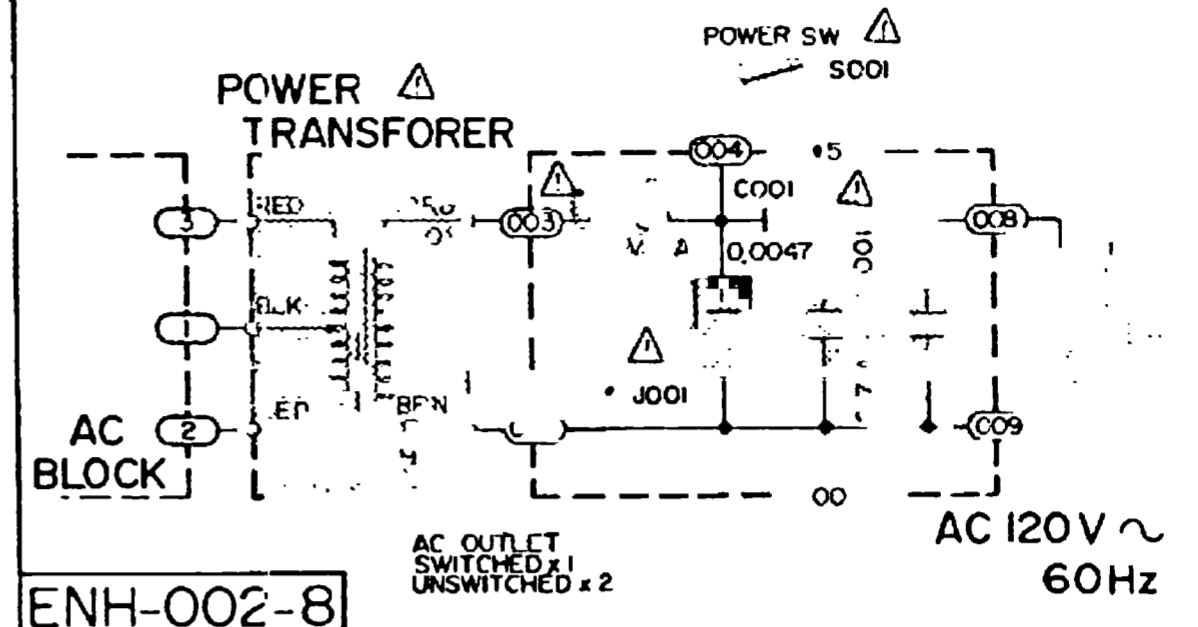
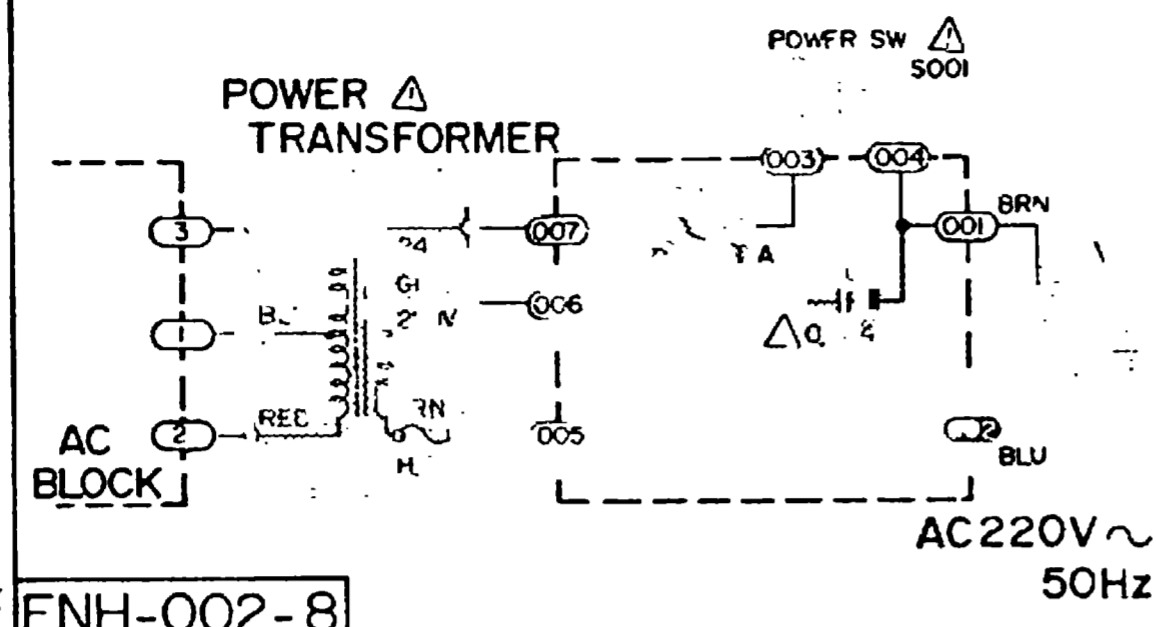
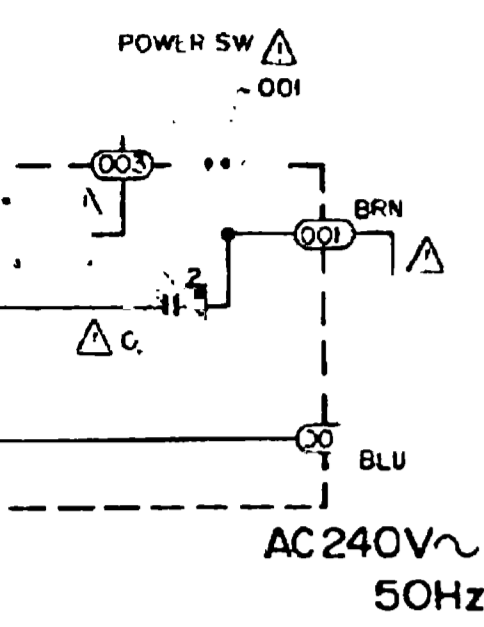
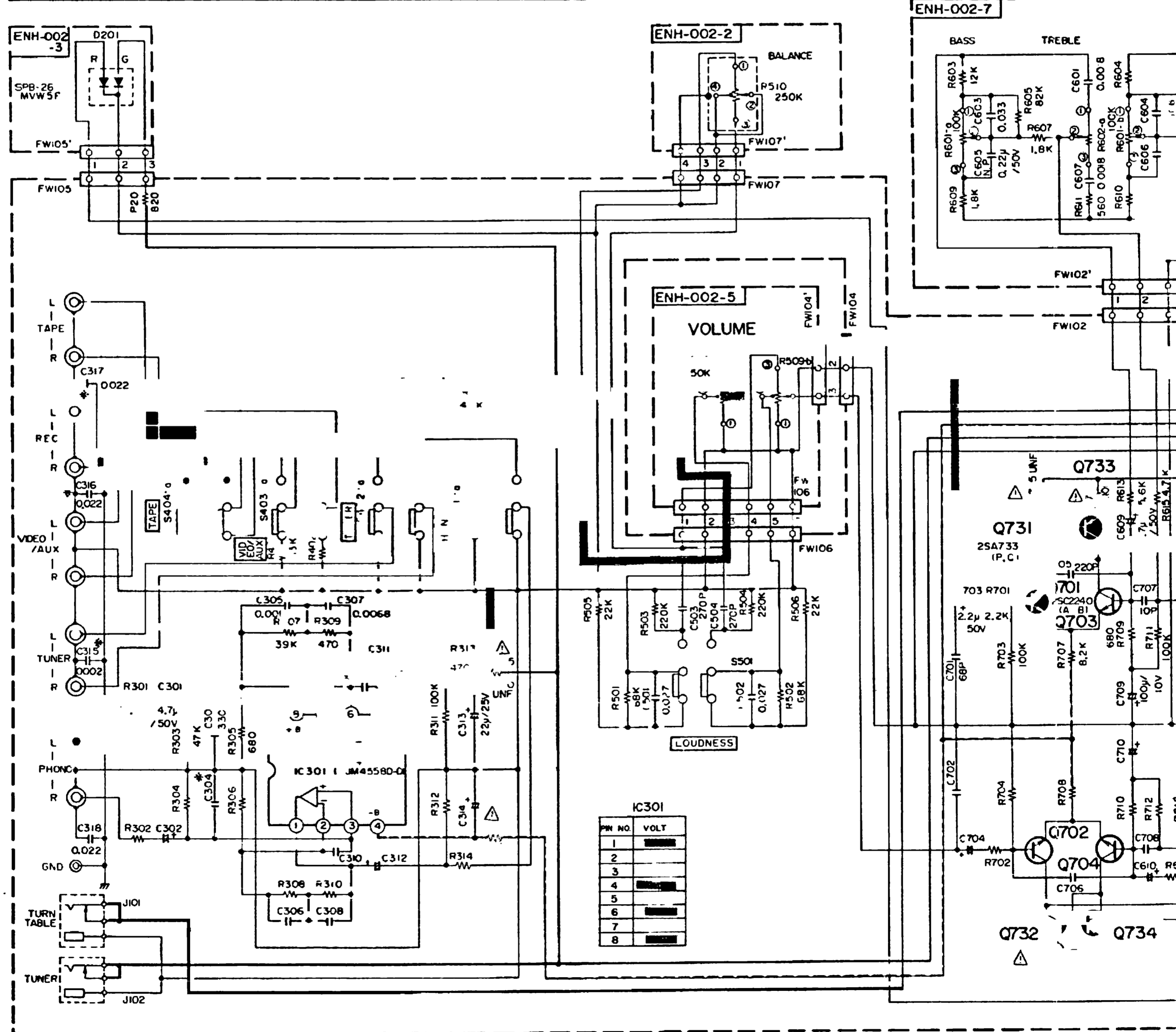
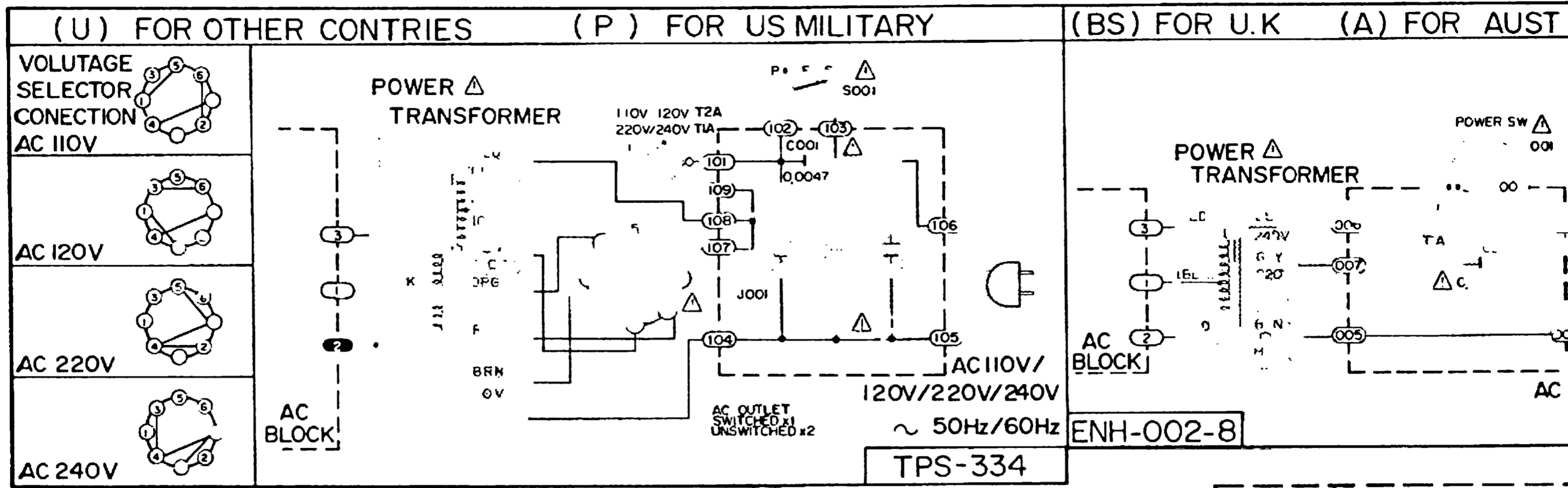

Printed Circuit Board Ass'y Location

P.C. Board Ass'y	Description	Page
ENH-002	P.C. Board Ass'y	6

Notes:

1. When replacing the parts in the darkened area and those marked with Δ , be sure to use the designated parts to ensure safety.
2. — indicates signal path.
3. — indicates positive B power supply.